

Application Guide

Manual / Kit Application



Powercrete J is a 100% Solids Epoxy used for corrosion and abrasion protection. This coating is applied over clean, bare steel and adjacent plant applied or mainline coatings. The application is fast and easy. Simply follow these guidelines.

1. Product

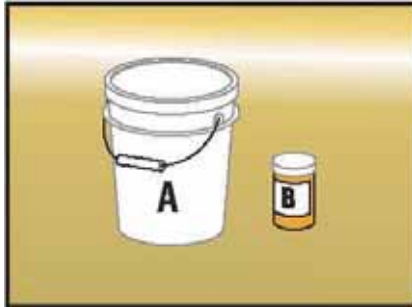

1. The 2-component epoxy coating is supplied in pre-measured kits. Part A (large container) is the Base and Part B (small container) is the curing agent.

2. Application Kit (ordered separately)



2. The "Application Kit"* contains a mask, Wet Film Gauge, Gloves, trowels, a PE stir stick, and abrasive paper.

3. Surface Preparation

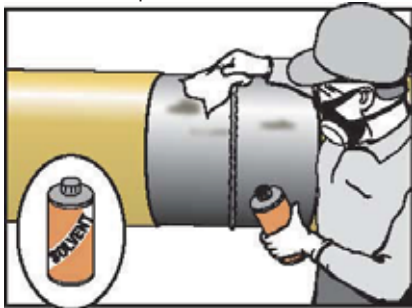

3. Insure that surfaces are clean of grease, oil, salts and other contaminants. If necessary, use Acetone, MEK or other suitable solvent. Perform cleaning when pipe is 3°C (5°F) above dew point.

4. Surface Preparation

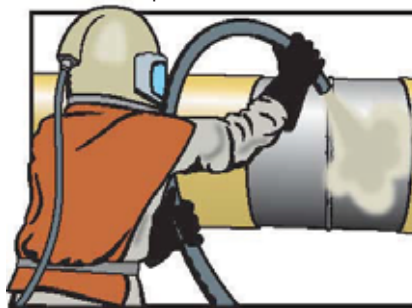

4. Blast clean surfaces to a near white ISO-8501, NACE No. 2, SA-21/2 (SSPC-SP 10) or better using particle blasting (sand or other). Sweep blast adjacent FBE or CTE coating. 50 mm (2") to either side of cutback (the bare steel area)

5. Surface Preparation

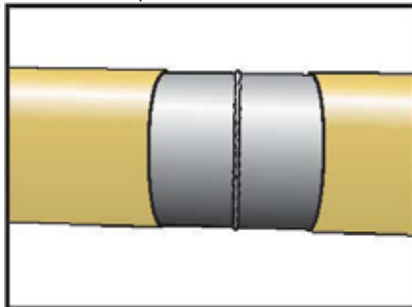

5. A 2.5-4 mil (63.5-101.6 micron) surface profile with sharp angularity. Burnishing or polishing must be avoided. Surface preparation can be controlled using surface profile tape. Dry surface and insure ideal surface preparation.

6. Surface Preparation

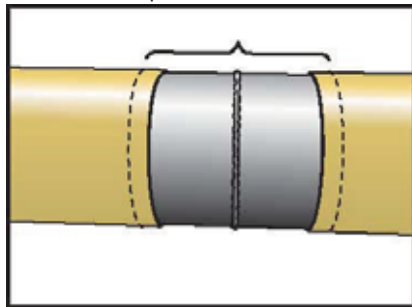

6. While not always necessary, preheating can be useful just prior to application.
A. To eliminate moisture, preheat the cutback area to approximately 40°C (104°F).
B. To accelerate curing, preheat the cutback area to approximately 90°C (194°F).

7. Combining & Mixing

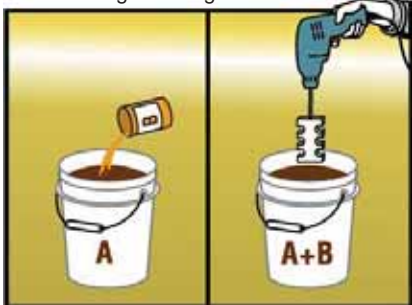

7. Warm parts A & B to 20°C (68°F) and mix by pouring all of part B into part A. Thoroughly scrape container and lid of B. Slowly begin mixing to avoid introducing air into the mixture.

8. Mixing

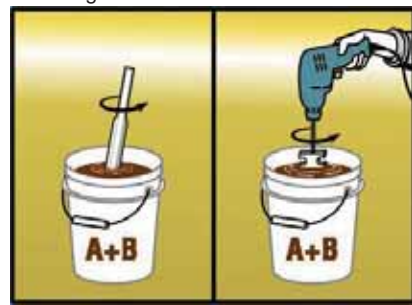

8. Use a mixing speed that uniformly blends the 2 parts, but does not create a vortex in the mixture or spillage.

Note: Between 20°C (68°F) & 40°C (105°F), mix for 2 - 3 minutes with a drill mixing paddle or 4 - 5 minutes with the stir stick. Blend both parts to create a uniform color with no streaks.

*: Berry Plastics does not supply these kits.

9

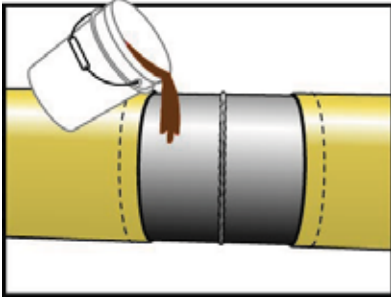

9. Reconfirm that the application temperature is above 10°C (50°F)* & 3°C (5°F)* above the dew point. Then slowly pour mixed epoxy onto pipe. See "Tips" below for additional suggestions.

10



10. Use trowels, brush or roller to apply required minimum thickness of coating to the Field Joint. Cover at least 50mm (2") of the adjacent mainline coating.

Tip: Masking tape may be applied to left & right 50mm (2") beyond cutback (see dotted lines) and later removed while the coating is still tacky to create a straight edge and neat appearance

***Note:** Powercrete J may be applied and cured at colder environmental temperatures if the pipe is heated during the application and cure..

11

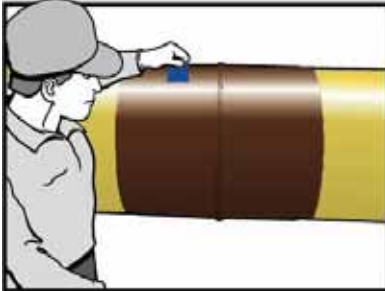

11. Use a Wet Film gauge to measure that the desired minimum thickness has been achieved. Double check around the weld to insure minimum desired thickness.

12

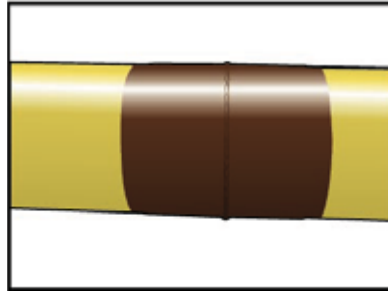

12. The curing rate* will vary according to pipe and ambient application temperature. Refer to curing rate chart to determine when to perform a Shore D check.

Storage

For optimum performance, store Powercrete® Epoxy products in a dry, well-ventilated area. Maintain products in original packaging and sealed until just before use. Avoid exposure to direct sunlight, rain, snow, dust or other adverse environmental conditions or contaminants.

NOTE: Avoid prolonged storage at temperatures above 40°C (104°F) or below 5°C (40°F).

Safety Guidelines

Important: Read the MSDS prior to using the products. Product installation should be done in well-ventilated area and in accordance with local health and safety regulations. These application guidelines are intended as a guide for standard products. Consult your Covalence Specialty Materials representative for specific projects or unique applications

Berry Plastics warrants that the product conforms to its chemical and physical description and is appropriate for the use stated on the technical data sheet when used in compliance with Berry Plastics written instructions. Since many installation factors are beyond the control of Berry Plastics, the user shall determine the suitability of the products for the intended use and assume all risks and liabilities in connection herewith. Berry Plastics liability is stated in the standard terms and conditions of sale. Berry Plastics makes no other warranty either expressed or implied. All information contained in this technical data sheet is to be used as a guide and is subject to change without notice. This technical data sheet supersedes all previous data sheets on this product.



DISTRIBUTED BY:
Protection Engineering
 PO Box 8996
 Pittsburg, CA 94565
 Tel: 800.878.8837
www.corrosioncoatings.com